



Parts: Econo-Finish® Dust Collectors

DC-16 Dust Collector

Item	Description	Part#
1	Blower, 120 V, 60 Hz, Single phase, 133 CFM	515761
2	Silencer cover	770963
3	Hush cloth, ½" x 7" x 8¼" (5 pieces)	580061
4	Line cord, 120 V	529601
5	Locking ring	504020
6	Drum, 16 gallon	504016
7	Wing nut, ¾"-16	553992
8	Flat washer, ¾"	552892
9 *	Filter cartridge	504771
10	Threaded rod	770067
11	Gasket, fan motor	524821
12	Lid weldment	770685

* Recommended spare part—Consumable wear item
 † Essential component to prevent downtime

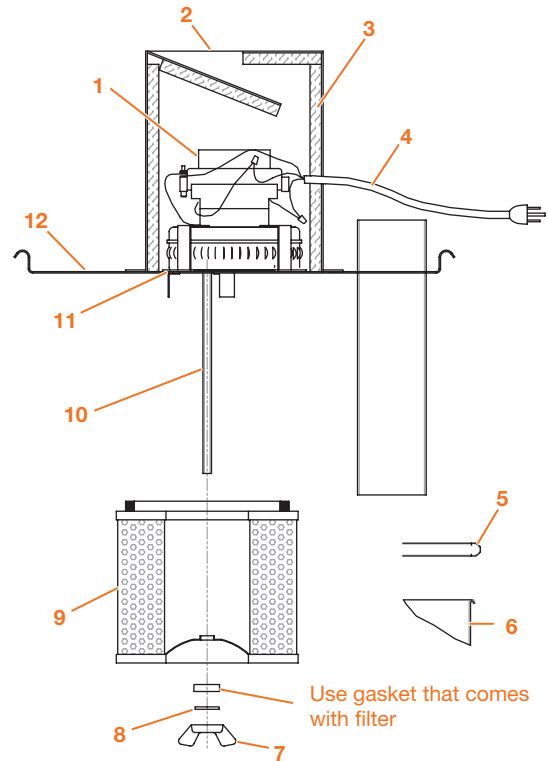

DC-30 Dust Collector

Item	Description	Part#
1	Blower, 120 V, 60 Hz, Single phase, 133 CFM	515761
2	Silencer cover	770963
3	Hush cloth, ½" x 7" x 8¼" (5 pieces)	580061
4	Line cord, 120 V	529601
5	Locking ring	504020
6	Drum, 30 gallon	504014
7	Wing nut, ¾"-16	553992
8	Washer, fender	552842
9 *	Filter cartridge	504751
10	Threaded rod	770067
11	Gasket, fan motor	524821
12	Lid weldment	770685

* Recommended spare part—Consumable wear item
 † Essential component to prevent downtime

